

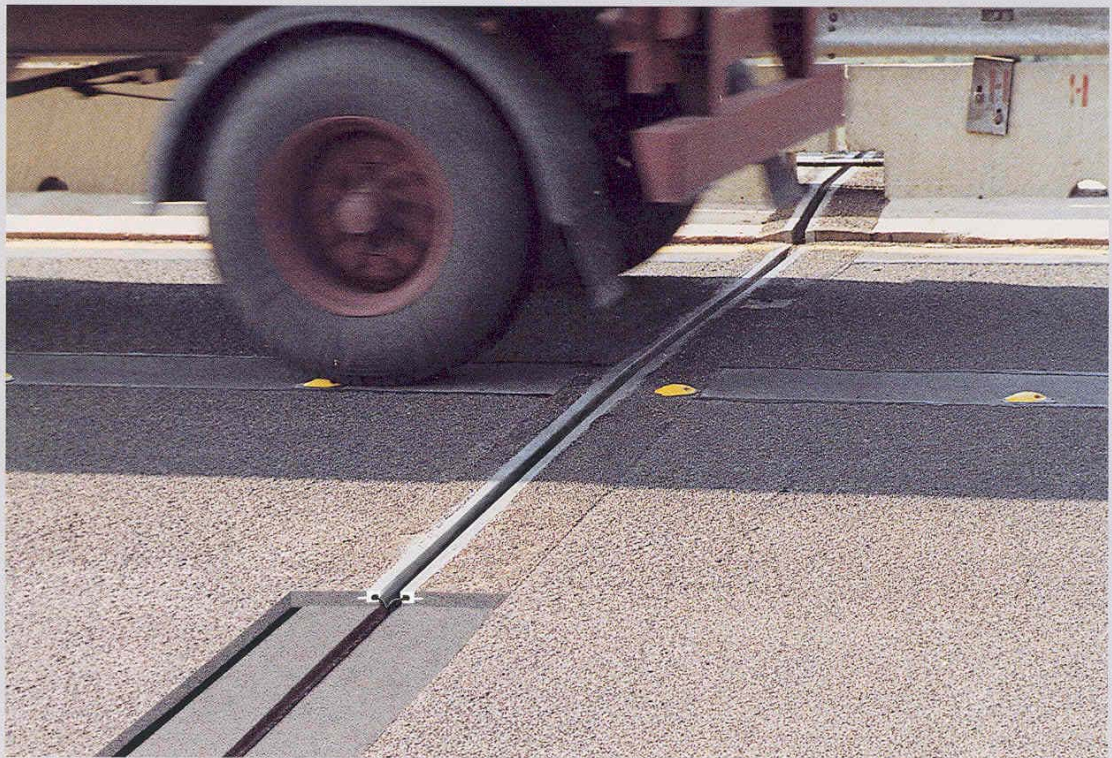

Bridge Accessories

MAURER Betoflex® Expansion Joints



with anchorage of polymeric concrete

MAURER SÖHNE
Innovations in steel



Since 1876



Wheel load testing at the TU Munich - test bench

Maurer Söhne counts among the leading manufacturers of bridge expansion joints and bridge bearings. Since 1982, the Betoflex® joint system has been marketed world wide with success, and to date more than 10,000 linear meters of expansion joints employing Betoflex® have been installed.

The Betoflex® expansion joint system was especially developed for the requirements in road and bridge structures as well as for industrial buildings subject to traffic loads.

System components:

The watertight expansion joint

Whereas in road and bridge construction, the Betoflex® system named B80B shall be applied that entails the MAURER strip seal technology, in ordinary buildings the MAURER compact joint type K30/50 is the suitable product.

The Betoflex® component

The anchorage of the steel edge beams is effected by the polymeric concrete Betoflex®. This type of concrete employs superior bonding characteristics to the adjacent contact areas.

Numerous tests at the Technological University of Munich as well as at the Technological University of Innsbruck confirmed the superior characteristics of the Betoflex® system.

Betoflex® is subject to continuous quality control, and its production is being supervised by third parties.

Betoflex® is a high grade polymeric concrete, being processed at room temperature, and designed for the anchorage of expansion joints in roads and bridges as well as other structures or buildings that are subject to traffic load.

Betoflex® employs the same superior bonding characteristics to steel and concrete as it is the case with conventional epoxy concrete. In addition, it reacts in a plasto-elastic way over the total temperature range, entailing a relatively small modulus of elasticity.

By means of the modification of the caoutchouc component, in comparison to mere epoxy concrete or cement, Betoflex® reacts in a much less brittle way. Thus, cracks in cross direction of the concrete edge beam that can often be observed when using epoxy concrete are avoided.

A particular strong point of Betoflex® - as opposed to conventional polymeric concretes using polyurethane - is its stability against saponification in respect to alkalis of moist concrete. This relies Betoflex® long term bonding characteristics.

The temperature expansion component α_t corresponds to approximately the five fold value of steel, respectively concrete. Due to the superior bonding characteristics of steel/concrete to Betoflex® as well as due to the elasticity of the polymeric concrete, a potential effect of shear in case of different expansions due to temperature is effectively avoided.

Expansion Joint B80B

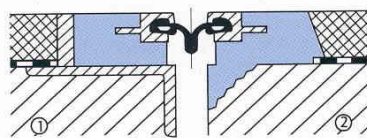

Compact Joint K30 A-B



- ① Betoflex® edge beam placed on existing steel substructure
- ② Betoflex® edge beam when being applied for the rehabilitation of concrete blockouts



Expansion Joint B80B

For the sealing of expansion joints in roads and bridges, nowadays almost exclusively strip seal systems are being applied. The MAURER strip seal system employs a special folding mechanism catering for permissible movements of 80mm and 100mm, effecting an absolute watertight clamping connection into the steel grooves of the adjacent steel edge beams made of steel grade S235JR. The shape of the edge beams thereby guarantees a continuous bonding over the entire length of the joint to the Betoflex® beam and thus to the adjacent structure.

Since the shape of the steel edge beam entails a continuous anchorage area, forces entering Betoflex® from the steel edge beams are being uniformly transferred, unlike in case of anchor studs that would concentrate the forces to discrete locations, i.e. where the studs are located. This uniform load transfer is one of the design features of the Betoflex® system. The waterproofing system is being integrated into the Betoflex® beam. By means of a skew cut, a long term bonding to the adjacent asphalt is being achieved. The expansion joint system B80B corresponds to the requirements in respect to ultimate limit state and fatigue state of expansion joints in bridges of class 60/30 according to German DIN 1072, respectively to the German specification TL/TP-FÜ 92.

Compact Joint K30/50 B

The watertight MAURER-Compact Joints are being applied for parking decks, ramps, pedestrian and bicycle bridges, store houses and the like, i.e. where speed and impact of vehicles is low. The strip seals cater for a movement of 30mm and 50mm and employ an almost smooth surface. The strip seals will be tightly connected to the adjacent edge beams made of aluminium (to be resistant against salt) or stainless steel. The continuous anchorage is being achieved by means of bonding between the Betoflex® beam and the edge beam made of steel or aluminium, respectively to the adjacent structure. The compact joint can be passed by heavy vehicles, fork lifters or other transport vehicles, as long as the field of application is limited to the ones mentioned initially.

Betoflex® Polymeric Concrete

Characteristics

- Cold curing 2 component polymeric concrete, that can be subjected to traffic after 12-24 hours of curing time
- Transfer of forces and from the expansion joints by means of bonding into the structure, and absorption of the impact-like road loads without long term deformation
- Absolute watertight connection of the Betoflex® beam to the steel edge beam of the expansion joint and to the waterproofing of the bridge structure
- Wear resistant surface
- Resistant against aggressive chemical components, like melting salt, gasoline, oils and acids
- Absorption of constrained stresses that result from differential temperature movements
- Only small blockout depth required (60mm for B80B, 45 mm for K30/50)
- In case of rehabilitation of bridges no jack hammers required (cutting asphalt suffices)
- No additional reinforcement or anchor studs required

Fields of Application

- Rehabilitation and replacement of damaged expansion joints in a very short period. Section wise installation facilitates installation while bridge is open to traffic
- Retrofitting structural gaps with expansion joints due to crack formation in the asphalt or in case of leakages
- Application of watertight expansion joints for a movement range of up to 100 mm, according to national specifications and individual requirements
- Installation of especially low noise emitting expansion joints by means of exact levelling of the edge beams with the adjacent Betoflex® layer
- Anti-skidding and noise dampening coating of the surface of an expansion joint with Betoflex®
- Formation of wear resistant, anti-skidding and watertight coatings
- Formation of the waterproofing of concrete bridges with Betoflex®

Material Characteristics of Betoflex®

Compression Strength ¹⁺²	N/mm ²	≥ 20
Modulus of Elasticity ¹⁺²	N/mm ²	≤ 6000
Pull-off Strength against Steel (sand blasted) ¹⁺³	N/mm ²	≥ 5
Pull-off Strength of Concrete ³	N/mm ²	≥ 1,5
Elongation at Break	%	≥ 8
Temperature expansion coefficient	1/K	< 60 x 10E-06
Pot time	min	app. 15
Water pressure stability at the connection to water proofing	bar	15
Colour		to order (standard is black)

¹ at room temperature

² in correspondance to DIN 1048, Parts 1 and 2

³ in correspondance to DIN ISO 4624

Processing

Polymeric concrete is being created by mixing the 2 components resin and hardener together with the mineral components. Contrary to most polymeric concretes, where the mineral components have to be heated in order to achieve the required short curing time, in case of Betoflex® the temperature of the structure will suffice, and no extra heating is required. This results in a high degree of environmental compatibility and superior constancy in quality.

When processing Betoflex® not only air humidity needs not be considered, but also Betoflex® is greatly insensitive to moisture in the structure. Pre-conditions are a dry surface at the time of pouring. The temperature of the structure should exceed 5°C, and the temperature of the Betoflex® mortar should exceed 20°C.

The adjacent concrete surface must have a minimum pull-off strength of 1.5 N/mm² (according to ZTV-SIB). Steel surfaces have to be sandblasted prior to pouring of Betoflex®.

Tests

The superior performance characteristics of Betoflex® were proven in numerous tests. Below we list an extract of the tests conducted:

1. Determination of the material characteristics of Betoflex®. Report of the Material Testing Institute for the Construction of Surface Transport, TU Munich, Nr.1362; 1990
2. Pull-off tests of Betoflex® with the Herion tool. Report of the Material Testing Institute for the Construction of Surface Transport, TU Munich, Nr.1362a; 1990
3. Wheel load testing and ultimate limit strength test. Report of the Material Testing Institute for the Construction of Surface Transport, TU Munich, Nr.1344;1990
4. Fatigue test and Ultimate Limit Strength test for the optimisation of the anchorage of the edge beam of Betoflex® expansion joints. Report of the TU Innsbruck; 1992
5. Wheel load testing for the optimisation of the connecting layer to Betoflex® expansion joints. *Report of the Material Testing Institute for the Construction of Surface Transport, TU Munich, Nr.1344; 1990 TU München, Nr. 1344; 1990.*

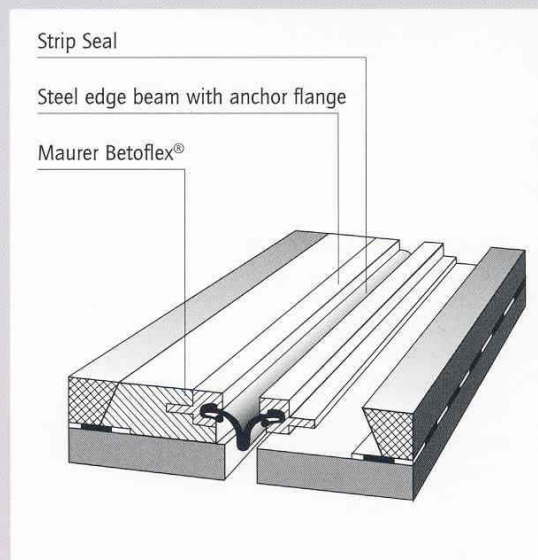

Fatigue test of the anchorage of the edge beam

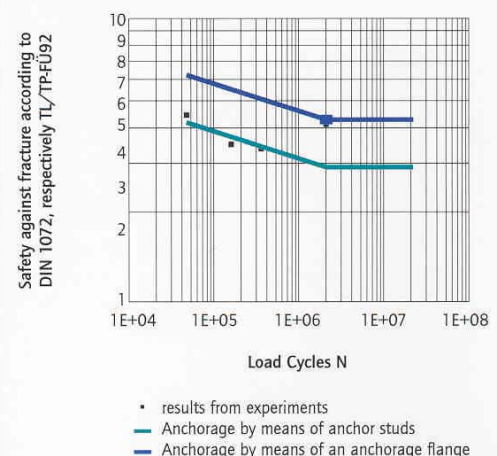

Maurer Söhne Head Office:
P.O. Box 44 01 45, D-80750 München
Frankfurter Ring 193, D-80807 München
Telephone (49)(89) 3 23 94-0
Fax (49)(89) 3 23 94-306
e-mail ba@mchn.maurer-soehne.de
Internet www.maurer-soehne.de

Maurer Söhne Main Branch Office:
P.O. Box 63 40, D-44520 Lünen
Zum Holzplatz 2, D-44536 Lünen
Telephone (49)(231) 4 34 01-0
Fax (49)(231) 4 34 01-11

Maurer Söhne Subsidiary Plant:
P.O. Box 55, D-02992 Bernsdorf
Kamenzer Str. 4-6, D-02994 Bernsdorf
Telephone (49)(3 57 23) 2 37-0
Fax (49)(3 57 23) 2 37-20